

DLG-S-005

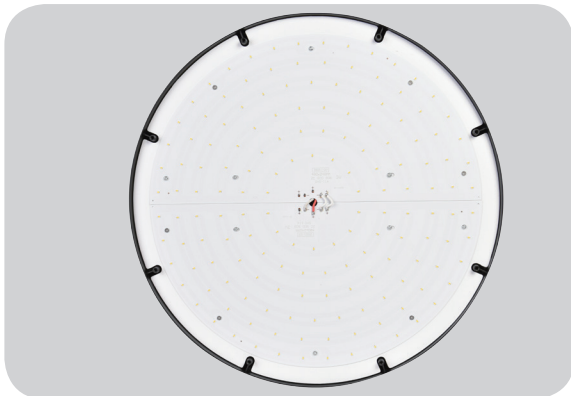

LED

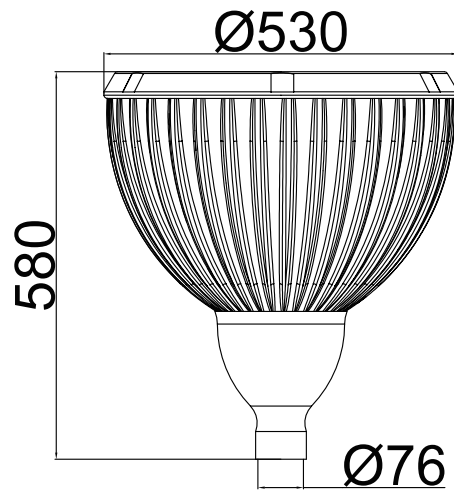
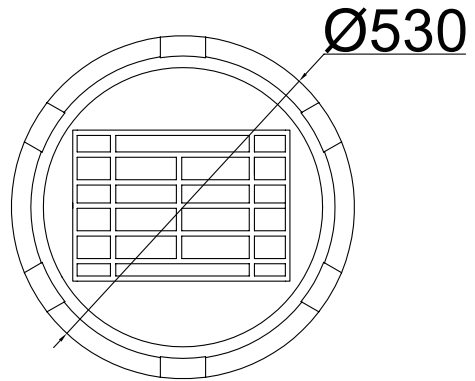

Prismatic PC diffuser

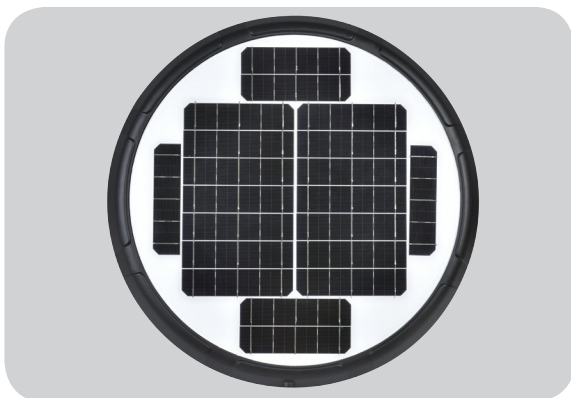

Solar panel



Switch

Application:



Walkways



Parks and Gardens



Car parks



Prestigious



Retail



Amenity

Features:

- Main body is made of Die-casting aluminum alloy.
- The diffuser is a Prismatic anti-UV injection polycarbonate for high efficiency and vandal resistance.
- Solar panel: Monocrystalline silicon-28W/5V
- 2835 led chip and LiFePO4 Lithium battery 36Ah/3.2V.
- 3000K & 6500K as regular ,other CCT options.
- Tamper proof fixings for increased vandal resistance.
- Anti-UV electrostatic powder spraying, regular color: Black
- IP65 rating water and rust proof protection.
- IK08 rating housing protection.
- Charge time: 5-6 hours
- Work time: three night by full charge
- Warranty is 3 years.



Specification:

Item No.	LED	Size	Wattage	CCT	CRI
DLG-S-005	2835	530*H580mm	15W	3000K & 6500K	Ra≥80